



COMPACT DRY PUMPING SYSTEMS  
**DRYTEL SERIES**



## Dry pumping units

The Drytel series of products are dry pumping systems that include an Adixen molecular drag pump (MDP) or a hybrid turbo pump (ATH) and an oil-free forepump. Designed to be used on a bench top or easily integrated into a system, these units provide a dry, clean vacuum from atmosphere to  $10^{-8}$  mbar (Torr).

## “Open Concept”: a new generation of Alcatel’s turbo pumping group...

### Benefits

- Flexible: many versions provide the most suitable configuration
- Compact
- Easy to maintain: direct access to the system components
- Cost effective

#### NO CONTAMINATION FROM INTERNAL LUBRICANTS

The two pumping stages working in series (MDP or ATH 31/AMD diaphragm pump) don't require any lubricant to operate, permitting use on ultra-clean processes.

#### HIGH RELIABILITY

The Drytel series incorporate well-proven vacuum pumps:

- Adixen molecular drag pump,
- Adixen compact hybrid turbo pump,
- Rugged diaphragm pumps.

#### COST-EFFECTIVE SOLUTION

The Drytel series is the least expensive solution to achieve a clean vacuum down to  $10^{-8}$  mbar (Torr).

## Applications

The Drytel series is recommended for all applications where a dry, clean vacuum is required, such as in industry (semiconductor, analytical instrumentation, pharmaceutical, chemicals, ...) and research and development laboratories.

They can be used in various types of applications:

- Backing of turbomolecular pumps
- Loadlock pumping
- Mass spectrometry
- Surface analysis
- Ion pump evacuation
- Cryopump regeneration
- Calibration
- Gas industry
- Gas lines



Application on a calibration bench

## Standard configurations: Drytel 1025

Based on the "Open Concept", this unique compact and flexible pumping system is available in several versions which can perfectly suit your needs.

According to your requirements, it may include :

- an Adixen MDP 5011 molecular drag pumps (7.5 l/s) or a compact ATH 31+ hybrid turbo molecular pump (30 l/s).
- a 4 m<sup>3</sup>/h AMD4 dry roughing pump, with a 10,000 hour maintenance interval.



Drytel 1025

## Chemical configurations: Drytel 1025 C

With the same "Open Concept", several versions are dedicated to the corrosives applications, with protection pumps devices.

According to your requirements, it may include :

- an Adixen MDP 5011 CP molecular drag pumps (7.5 l/s) or a compact ATH 31 C hybrid turbo molecular pump (30 l/s).
- a 4 m<sup>3</sup>/h AMD4C dry roughing pump, with a 10,000 hour maintenance interval.
- a purge device protect the ball bearing of the turbo molecular pump.
- an additional purge on the high pressure stage of the AMD4C is an option for the pumping of corrosive gases and to avoid gas condensation.



Drytel 1025 C

DRYTEL SERIES

Standard configurations: Drytel 1025



The Drytel 1025 is a small, robust pumping system which provides a solution for backing turbomolecular pumps or pumping a system down to  $10^{-8}$  mbar (Torr). This flexible system is available in several versions which can perfectly suit your needs.



Primary pump: AMD 1/AMD 4 and Turbo: MDP 5011/ATH 31+



Primary pump: AMD 4C and MDP 5011 CP/ATH 31 C

## Standard versions



Drytel 1025 with MDP 5011 and AMD1



Drytel 1025 with MDP 5011 and AMD4



Drytel 1025 with ATH 31 + and AMD1



Drytel 1025 with ATH 31 + and AMD4

## Chemical versions



Drytel 1025C with MDP 5011 CP and AMD4C



Drytel 1025C with ATH 31C and AMD4C

DRYTEL SERIES

Technical data

Pump down curves on a 30 l volume of N<sub>2</sub>

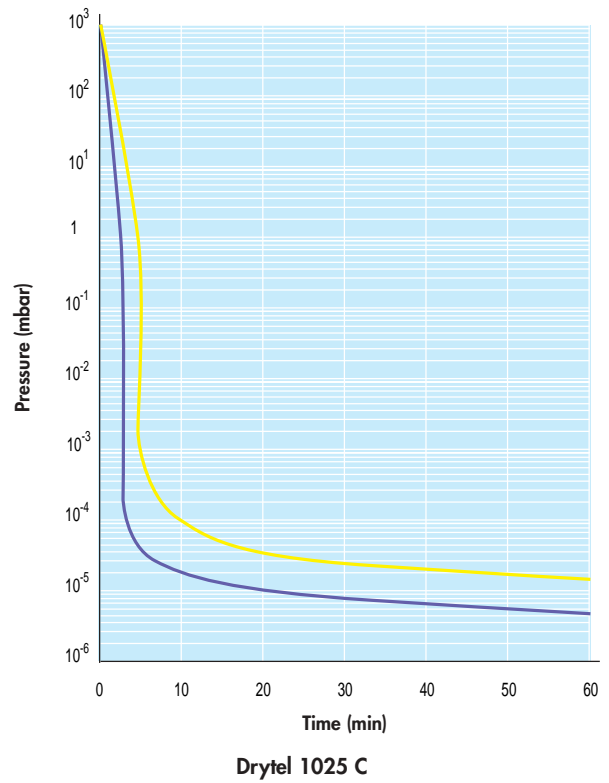
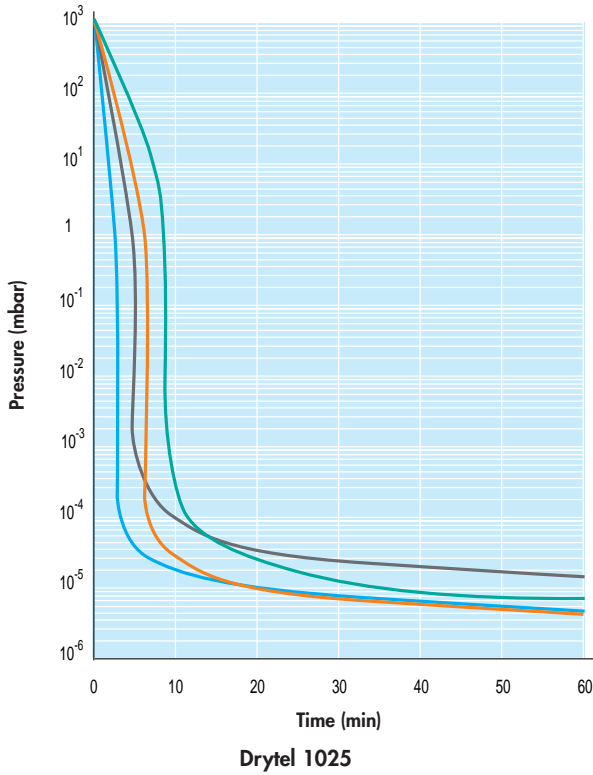

Pumping speed / Inlet pressure (N<sub>2</sub>)

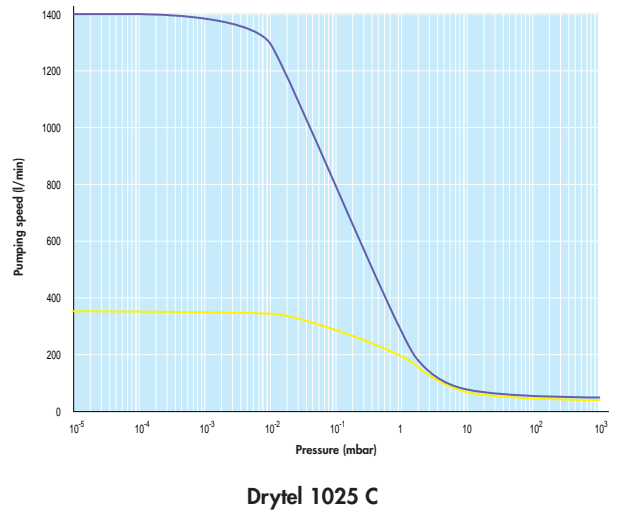
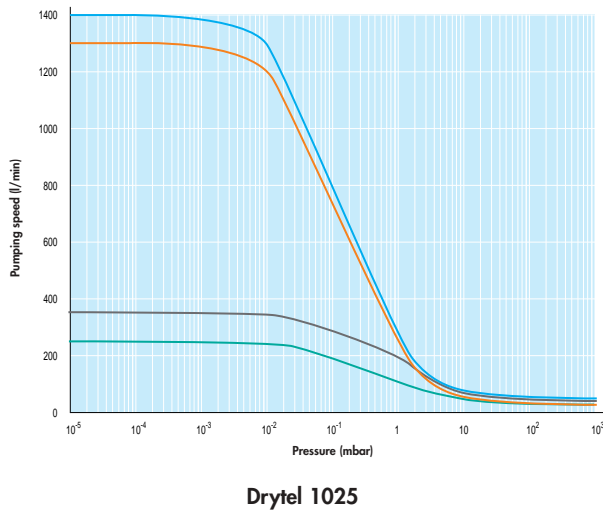

- ATH 31+ and AMD 1 on 30 L
  - MDP 5011 and AMD1 on 30 L
- ATH 31+ and AMD4 on 30 L
  - MDP 5011 and AMD4 on 30 L
  - ATH 31 C and AMD4C
  - MDP 5011 CP and AMD4C

## Drytel 1025 - Drytel 1025 C : technical data

Drytel		Unités	1025 standard				1025 C	
High vacuum pump			MDP 5011		ATH 31+		MDP 5011CP	ATH 31C
Primary pum			AMD1	AMD4	AMD1	AMD4	AMD4C	AMD4C
H.P. pump. speed (60 Hz)		m <sup>3</sup> /hr	1.4	4	1.4	4	4	
L.P. pump. speed	N2	l/s	7.5		30		7.5	30
	He	l/s	4		20		4	20
	H2	l/s	3		14		3	14
Ult. pressure		mbar	10 <sup>-6</sup>		<10 <sup>-8</sup> (*)		<10 <sup>-5</sup> (**)	<10 <sup>-8</sup> (**)
Start-up time		min	2		2		2	
Cooling system			Air		Air		Air	
Maximum ambient temperature		°C	0 to 40		0 to 40		0 to 40	
Maximum power consumption		VA	< 160	< 310	< 160	< 310	< 310	
Weight		kg (lb)	16 (34)	26 (56)	16 (34)	26 (56)	26 (56)	
Standard flange			63 ISO-K		63 ISO-K or 63 CF-F		63 ISO-K	63 ISO-K or 63 CF-F
Size	L	mm	385	385	385	385	385	385
	W	mm	305	410	305	410	410	410
	H	mm	265	265	240	240	265	240

\* : with CF-F 63 housing after 48 hours of baking according to Pneurop standard.  
 \*\* : with purge.

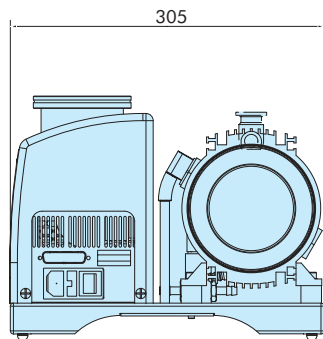

AMD1 version

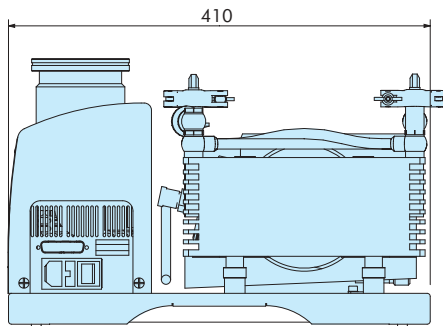
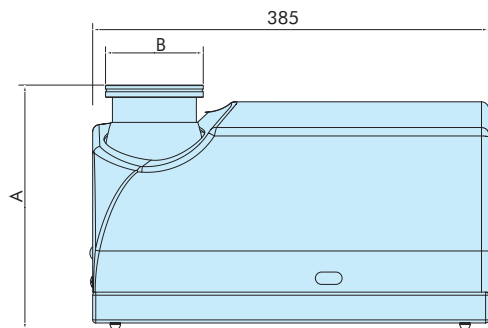

AMD4 or AMD4C versions

Inlet flange	A	B
MDP 5011 : DN 63 ISO K-F	265	95
MDP 5011 CP : DN 63 ISO-KF	265	95
ATH 31+ : DN 63 ISO-KF	240	95
ATH 31C : DN 63 ISO-KF	240	95
ATH 31+ : DN 63 CF-F	240	113

DRYTEL SERIES

## Drytel 1025 and 1025 C : options and accessories

It is possible to order the Drytel 1025 with several types of options. They must be incorporated at time of original order.

### Options Drytel 1025



- Automatic gas ballast: improves the pumping of light gases and reduces condensation inside the Drytel.
- Exhaust connection: allows the collection of pumped gases to prevent release into the atmosphere.



- Interface board: allows the remote operation of the Drytel (start/stop and monitoring of the pumping system status), also available on Drytel 1025 C.

### Options Drytel 1025 C

Several options are possible:

- Purge connection: it can be equipped with a quick and anti such back connector or a DN16 electrical valve (24 V DC supplied by customer) normally closed.

- An additional purge (100 sccm) on the high pressure stage of the AMD4C for pumping of corrosive gases and avoid condensation.



Quick connector



DN16 Electrical valve



Purge on high pressure stage

### Accessories for Drytel 1025 and 1025 C

The following accessories are available for the Drytel 1025 and 1025 C. In particular, an inlet screen should be used to prevent foreign material from entering the pump.

Description	P/N
Inlet screen (DN 63 ISO-K) - 2.5 mm mesh size	102565
Dense mesh filter (DN 63 ISO-K) - 20 µm mesh size	102668
Aluminium centering ring (DN 63) special for MDP 5011 (without o-Ring)	063212



Standard and dense mesh inlet screen

## Drytel 1025 : ordering information

D025

Drytel 1025	
Code	D025

Secondary pumping		
MDP 5011	ATH 31+	ATH 31+ CF-F
Code	A	B G

Primary pumping	
1 m <sup>3</sup> /h	4 m <sup>3</sup> /h
Code	S Q

Automatic gas ballast	
Yes	No
Code	L N

Interface board	
Yes	No
Code	P N

Exhaust	
Standard	DN 16
Code	S D

Tension	
110/130 V - 50/60 Hz	200/240 V - 50/60 Hz
Code	7 8

Cable Type				
U.S.A.	France/Germany	U.K.	Italy	Switzerland
Code	1	2	3	4 5

For example  
You need ...

Drytel D025  
Secondary pumping **A**  
Primary pumping **S**  
Gas ballast **L**  
Interface board **P**  
Exhaust DN 16 **D**  
110/130 V - 50/60 Hz **7**  
U.S.A. **1**

= D025 **A S L P D 7 1 0**



## Customization

If you do not see the configuration that you need, we can customize the pumping system. We offer product customization and integration of accessories, such as:

- Valves
- Gauges

Please consult us.



#### CHINA

Alcatel Vacuum Technology Shanghai  
Tel: (86) 21 5027 0628  
Fax: (86) 21 3895 3815

#### FRANCE

Alcatel Vacuum Technology France  
Tel: 33 (0) 4 50 65 77 77  
Fax: 33 (0) 4 50 65 77 89

#### GERMANY

Alcatel Hochvakuum Technik GmbH  
Tel: (49) 9342 96 10 0  
Fax: (49) 9342 96 10 30

#### ITALY

Alcatel Vacuum Systems S.p.a.  
Tel: (39) 039 686 3855  
Fax: (39) 039 667 125

#### JAPAN

Alcatel Japan  
Tel: (81) 44 797 5920  
Fax: (81) 44 797 5932

#### KOREA

Alcatel Vacuum Technology Korea  
Tel: (82) 2 409 6277  
Fax: (82) 2 409 6279

#### NETHERLANDS

Alcatel Vacuum Technology  
Netherlands  
Tel: (31) 306 35 13 60  
Fax: (31) 306 35 12 21

#### SINGAPORE

Alcatel Singapore Pte Ltd  
Tel: (65) 6254 0828  
Fax: (65) 6254 7018

#### TAIWAN

Alcatel Vacuum Technology Taiwan  
Tel: (886) 3 5599 230  
Fax: (886) 3 5599 231

#### UNITED KINGDOM

Alcatel Vacuum Technology (U.K.)  
Tel: (44) 1 506 418 000  
Fax: (44) 1 506 418 002

#### USA

Alcatel Vacuum Products  
Tel: (1) 781 331 4200  
Fax: (1) 781 331 4230



**Alcatel Vacuum Technology**

98 Avenue de Brogny - BP 2069 - 74009 Annecy Cedex - France - Tel.: 33 (0) 4 50 65 77 77 - Fax: 33 (0) 4 50 65 77 89

[www.adixen.com](http://www.adixen.com)